

freerider[®]

SPARE PARTS MANUAL

FRG034BRUKNA

FR1



INDEX

1. **HANDLEBAR ASSEMBLY**-----P.4
2. **CHASSIS COVER ASSEMBLY**-----P.6
3. **FRONT CHASSIS ASSEMBLY**-----P.8
4. **REAR CHASSIS ASSEMBLY-DRIVE SYSTEM**--P.10
5. **STEERING**-----P.12
6. **SEAT ASSEMBLY**-----P.14
7. **CONSOLE AND WRING SYSTEM**-----P.16

1. HANDLE BAR ASSEMBLY

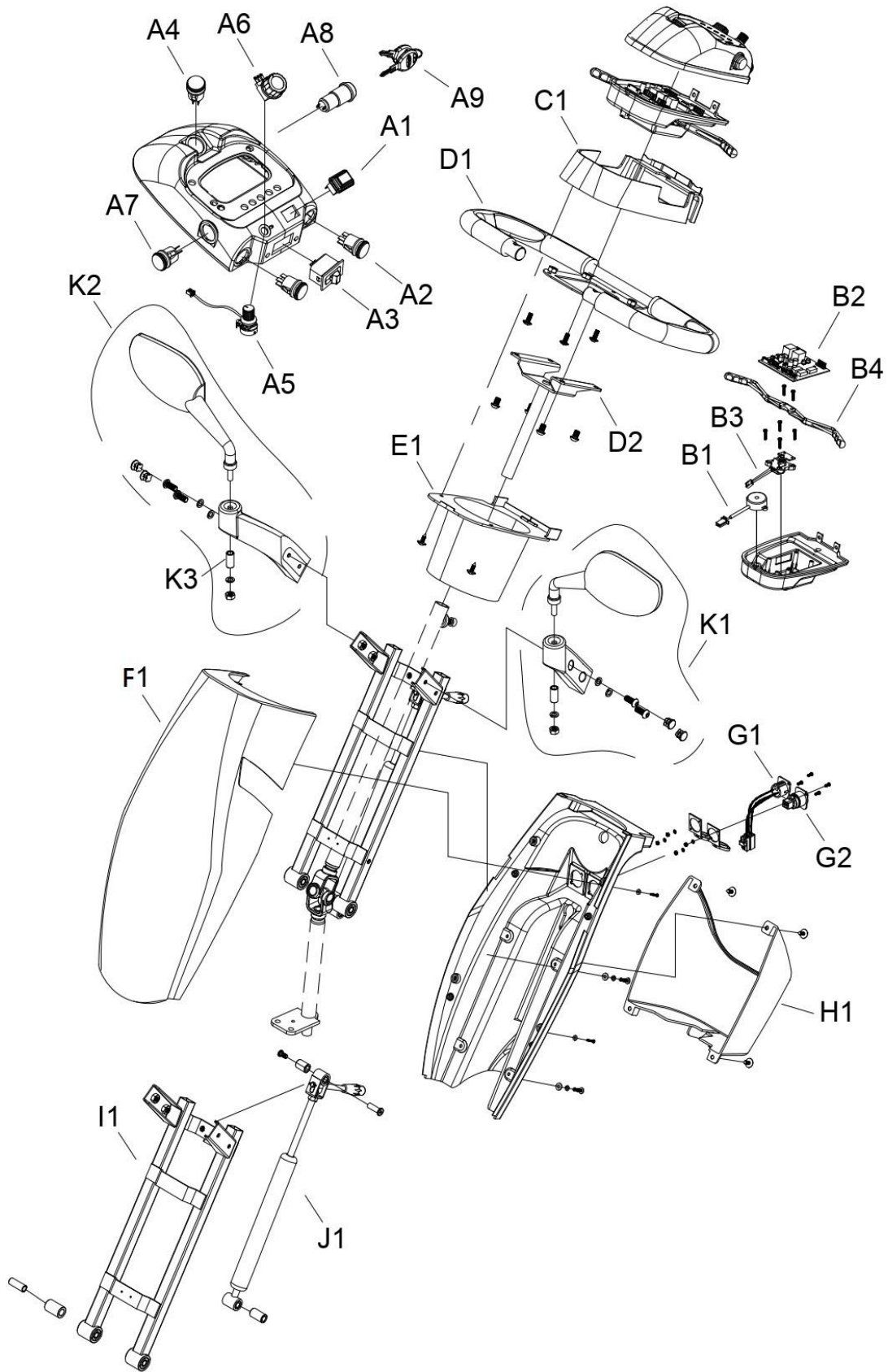

1. HANDLE BAR ASSEMBLY

販售 Selling	項目 ITEM	品號 Part Number	中文品名 Part Name-CN	英文品名 Part Name-EN	數量 QTY	備註 Remark	GBP
	A1-K3						
	A1-A8	AAA1-0300-◎	把手上蓋小總成	Top console cover assy.	1	◎=CR : Metallic orange、 MG : Metallic gray iron、 WH : white	
	A1	PKE1-0111	大燈開關	Headlight switch	1		
	A2	PKE1-0113	喇叭開關	Horn button	2		
	A3	PKE1-0114	方向燈開關	Indicator switch	1		
	A4	PKE1-0115	警示燈開關	Warning switch	1		
	A5	PAE1-0105-MO	20KVR小總成	20KVR Potentiometer	1	W/speed knob	
	A6	PP01-0501	速度旋鈕	Speed knob	1		
	A7	PKE1-0112	全半速開關	HI/LO Speed switch	1		
	A8	PM01-0100	鑰匙開關	Key switch	1		
	A9	PM90-0900	鑰匙	Key	1		
	B1-B4	AAA2-0210-OD	把手下蓋小總成	Console bottom cover assy.	1		
	B1	PKE1-0605	喇叭	Horn	1		
	B2	PAE1-0321	PCB板	P.C.B	1		
	B3	PAE1-0207	5KVR總成	5KVR Potentiometer	1		
	B4	PP02-0601	前後撥桿	Wig wag accelerator	1		
	C1	AAA3-0100-◎	把手頭蓋	Console cover	1	◎=CR : Metallic orange、 MG : Metallic gray iron、 WH : white	
	D1	PM02-0516	握式把手	Delta handlebar	1		
	D2	PM02-0518	把手支架	Delta handlebar frame	1		
	E1	PP01-1000	把手伸縮遮蓋	Tiller black cover	1		
	F1	PP03-0117-◎	把手前蓋	Tiller front cover	1	◎=CR : Metallic orange、 MG : Metallic gray iron、 WH : white	
	G1-G2	AA02-1300	把手後蓋(中蓋)總成	Tiller rear cover assy.	1		
	G1	PAE1-0412-A00	充電座小總成	Charge socket assy.	1		
	G2	PKE1-0909	USB座	USB charge socket	1		
	H1	AA02-1400	置物蓋小總成	Storage	1		
	I1	PA01-B100	把手架小總成	Tiller frame assy.	1		
	J1	PA03-A200	油壓桿小總成	Cylinder assy.	1		
	K1	PA90-0800-L	後照鏡小總成-左	Mirror(Left)	1		
	K2	PA90-0800-R	後照鏡小總成-右	Mirror(Right)	1		
	K3	PM00-0122	套筒	Tube	1	ψ14×ψ8×25.8L	

2. CHASSIS COVER ASSEMBLY

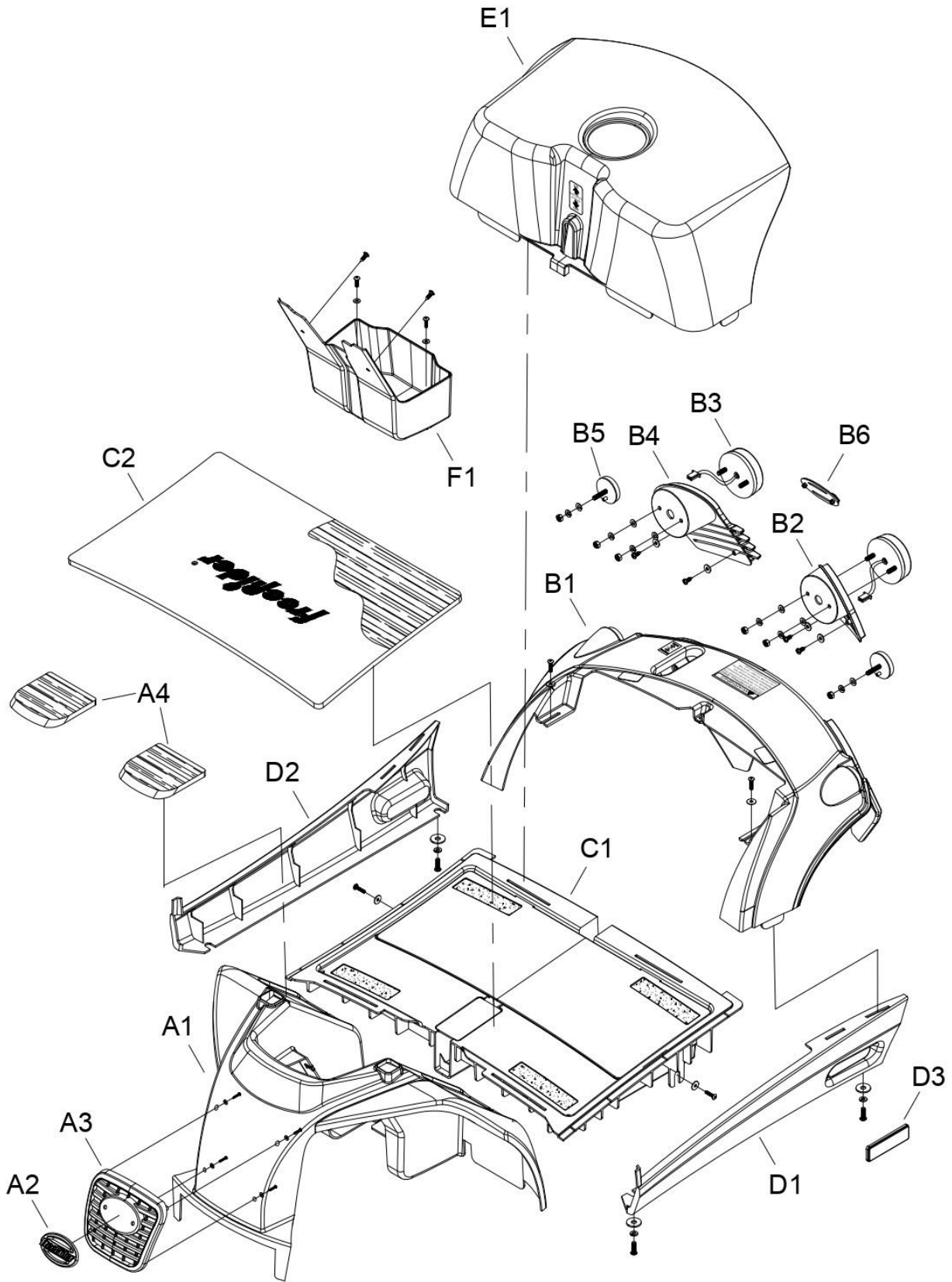

2. CHASSIS COVER ASSEMBLY

販售 Selling	項目 ITEM	品號 Part Number	中文品名 Part Name-CN	英文品名 Part Name-EN	數量 QTY	備註 Remark	GBP
	A1-F1						
	A1-A3	AA04-3000-◎	前車殼總成	Front chassis cover assy.	1	◎=CR : Metallic orange 、 MG : Metallic gray iron 、 WH : white	
	A1	PP04-0142-◎	前車殼	Front chassis cover	1	◎=CR : Metallic orange 、 MG : Metallic gray iron 、 WH : white	
	A2	PL94-0300	LOGO銘版	Logo plate	1	Freerider	
	A3	PP04-3000	前空氣飾板	Plastic grill	1		
	A4	PP04-0411	止滑踏墊	Foot mat	2		
	B1-B6	AA05-2600-◎	後車殼總成	Rear chassis cover assy.	1	◎=CR : Metallic orange 、 MG : Metallic gray iron 、 WH : white	
	B1	PP05-0138-◎	後車殼	Front chassis cover	1	◎=CR : Metallic orange 、 MG : Metallic gray iron 、 WH : white	
	B2-B3	PA07-A204-L	後大燈小總成-左	Tail light (Left)	1		
	B2	PA05-A500-L	後燈座-左	Rear light bracket(Left)	1		
	B3	PKE3-0205	後大燈	Tail light	1		
	B3-B4	PA07-A204-R	後大燈小總成-右	Tail light (Right)	1		
	B4	PP05-0900-R	後燈座-右	Rear light bracket(Right)	1		
	B5	PP05-0403-R	反光片	Reflector (Red)	2		
	B6	PL94-0300-PT	LOGO銘版	Logo plate	1	Freerider	
	C1	AA06-0400	腳踏板總成	Footplate cover assy.	1		
	C2	PP04-0528	地毯	Carpet	1		
	D1	AA07-0100-L-◎	踏板總成-左	Stamp cover assy.(Left)	1	◎=CR : Metallic orange 、 MG : Metallic gray iron 、 WH : white	
	D2	AA07-0100-R-◎	踏板總成-右	Stamp cover assy.(Right)	1	◎=CR : Metallic orange 、 MG : Metallic gray iron 、 WH : white	
	D3	PP05-0411	側反光貼片	Reflector	1		
	E1	PA04-A203	電池蓋小總成	Battery cover assy.	1		
	F1	PA04-B300	置物籃	Storage	1		

3. FRONT CHASSIS ASSEMBLY

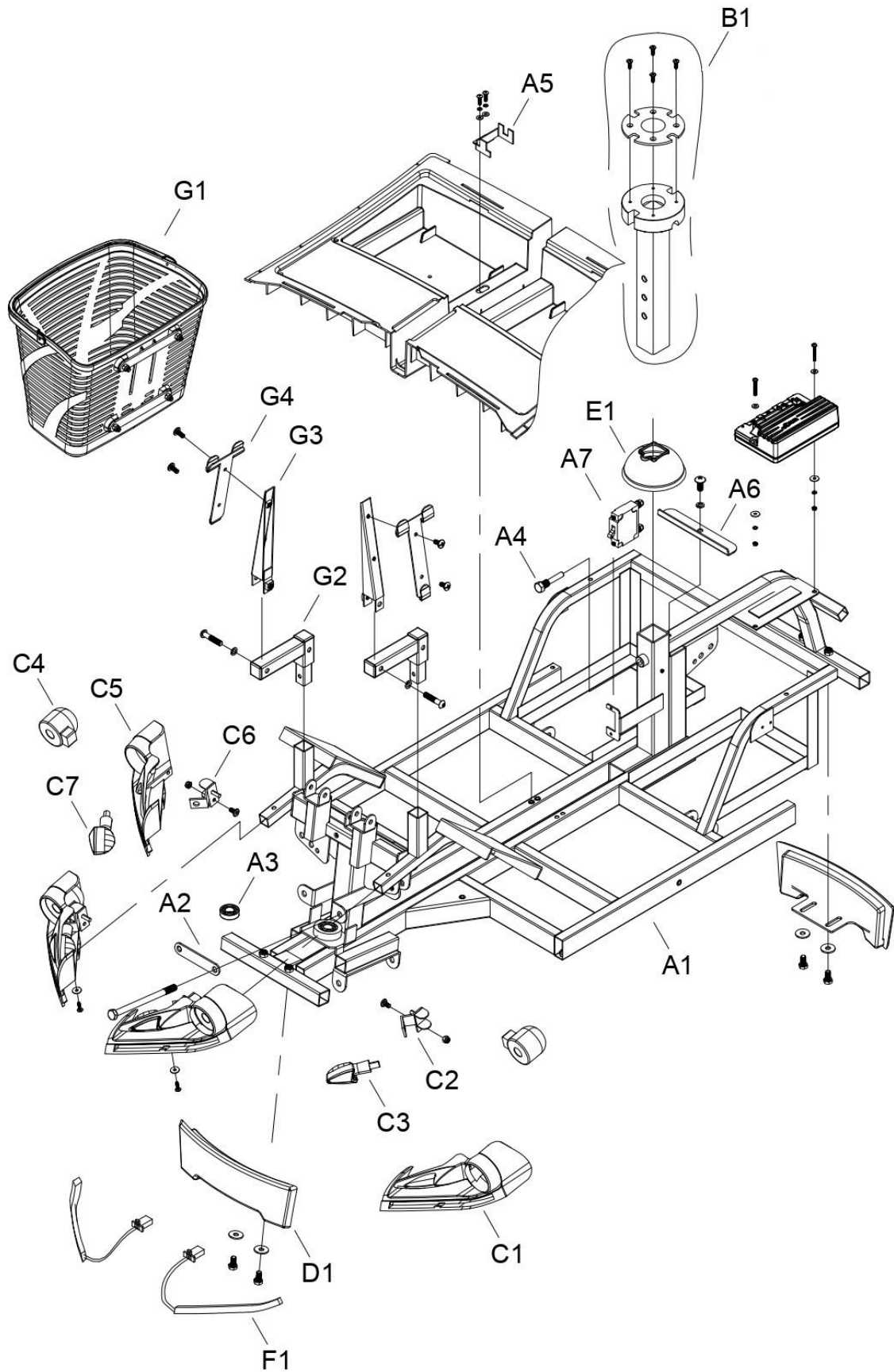

4. REAR CHASSIS ASSEMBLY-DRIVE SYSTEM

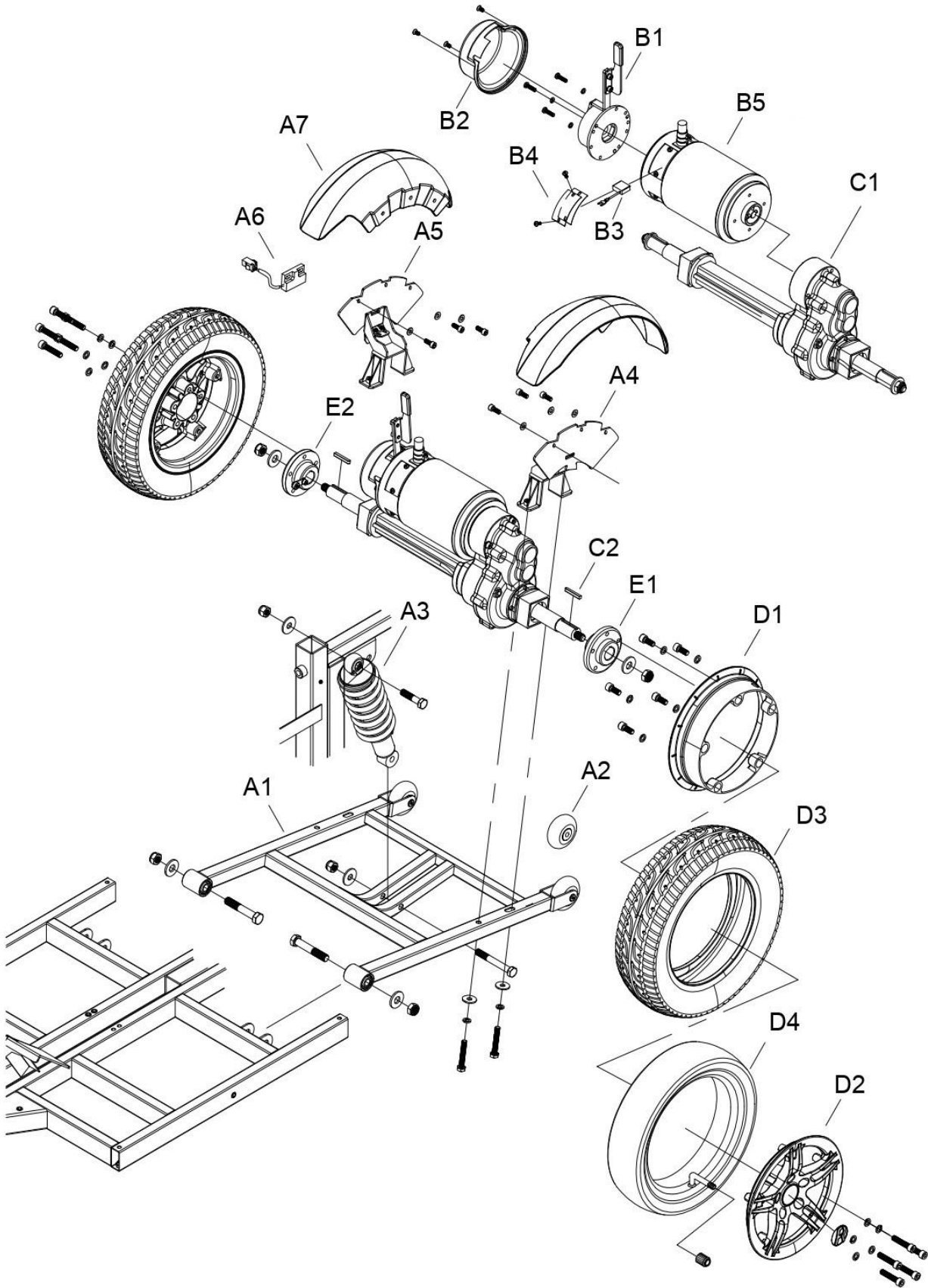

5. STEERING

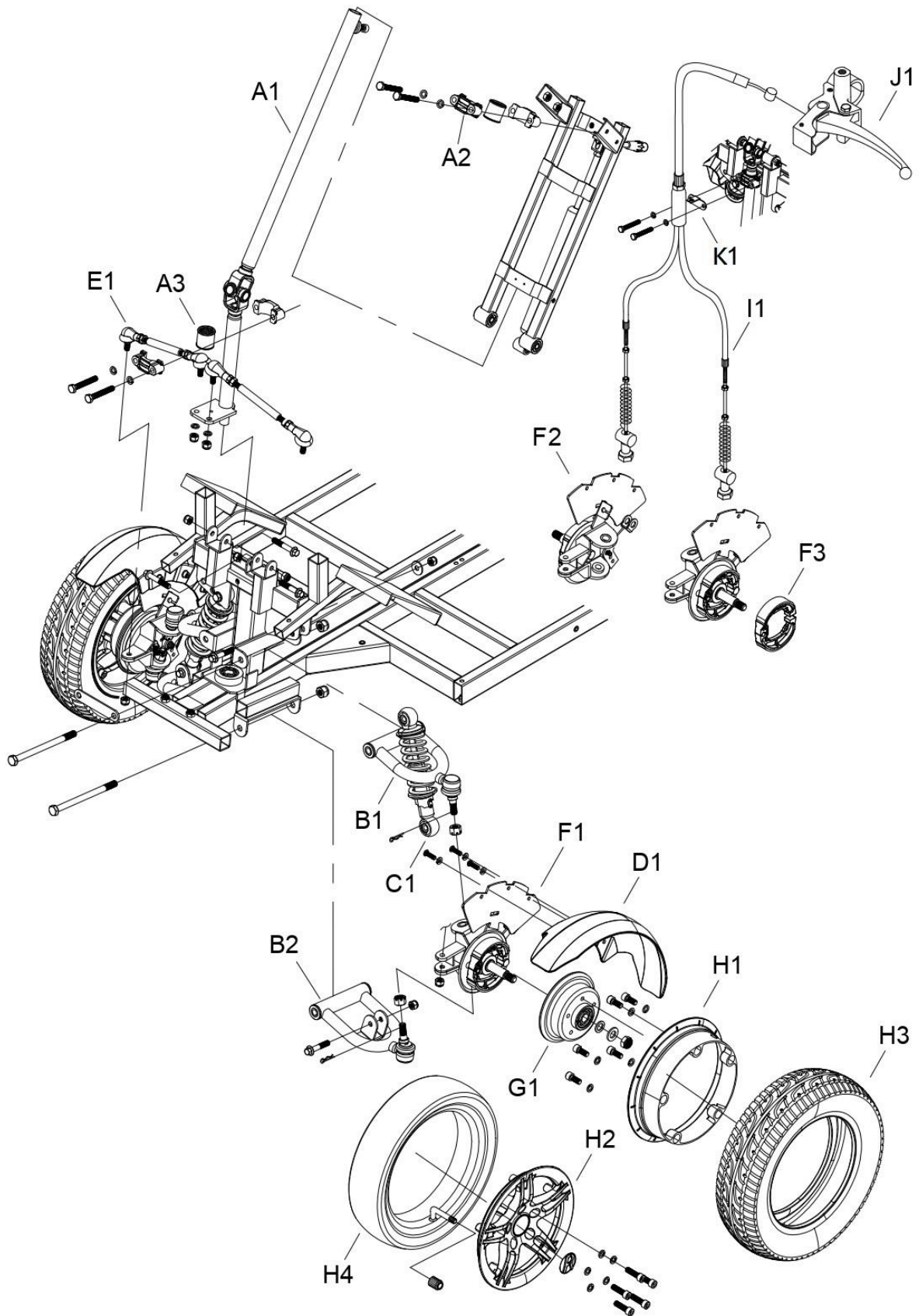

6. SEAT ASSEMBLY

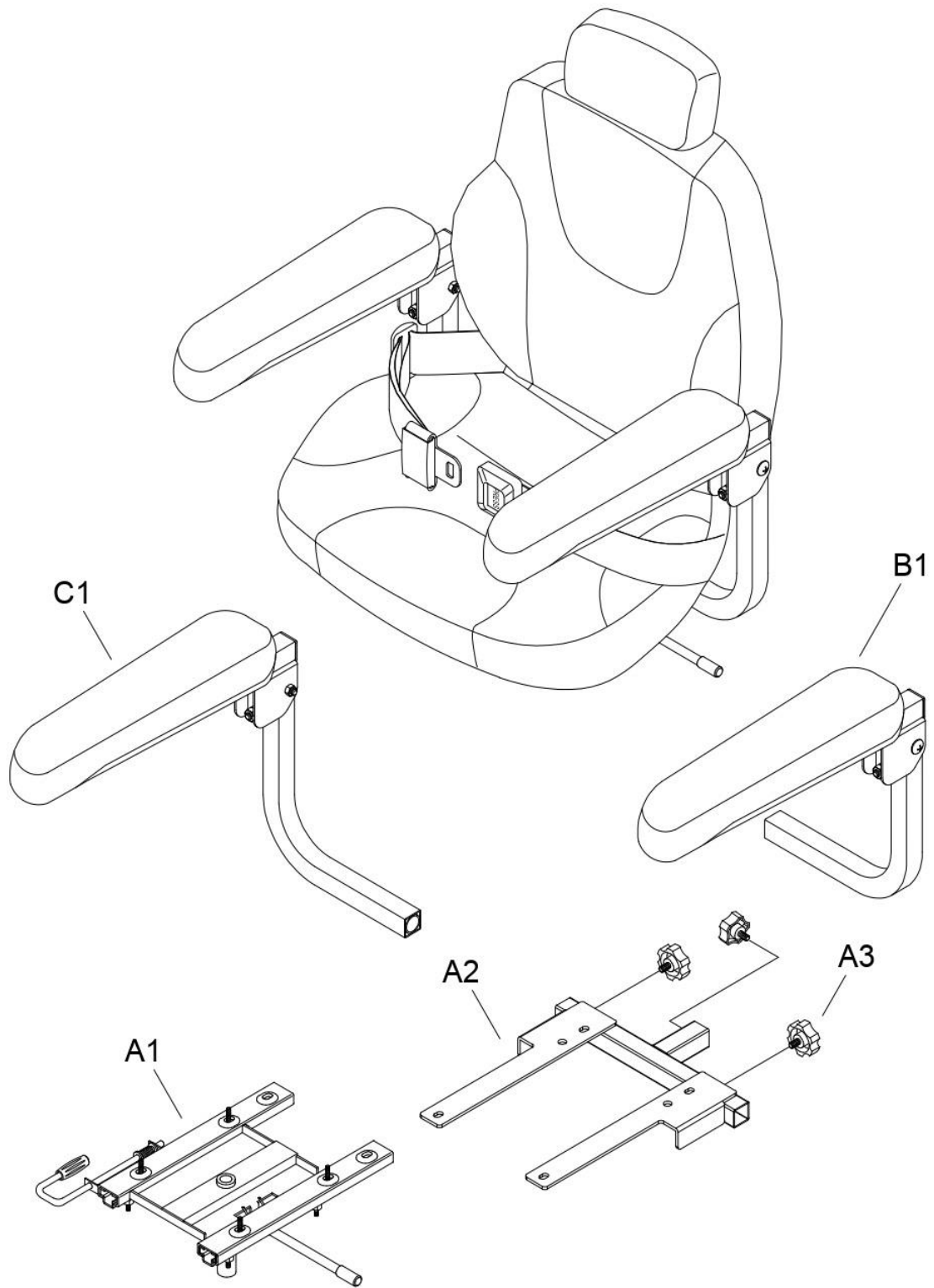

7. CONSOLE AND WIRING SYSTEM

