

FreeRider®

SPARE PARTS MANUAL

Kensington-S FRD044BRUKNB
FR510-DXs2b



INDEX

1. **HANDLEBAR ASSEMBLY**-----
P.4
2. **CHASSIS COVER ASSEMBLY**-----
P.6
3. **FRONT CHASSIS ASSEMBLY**-----P.8
4. **REAR CHASSIS ASSEMBLY-DRIVE SYSTEM**--P.10
5. **STEERING**-----
P.12
6. **SEAT ASSEMBLY**-----
P.14
7. **CONSOLE AND WRING SYSTEM**-----
P.16

1. HANDLEBAR ASSEMBLY

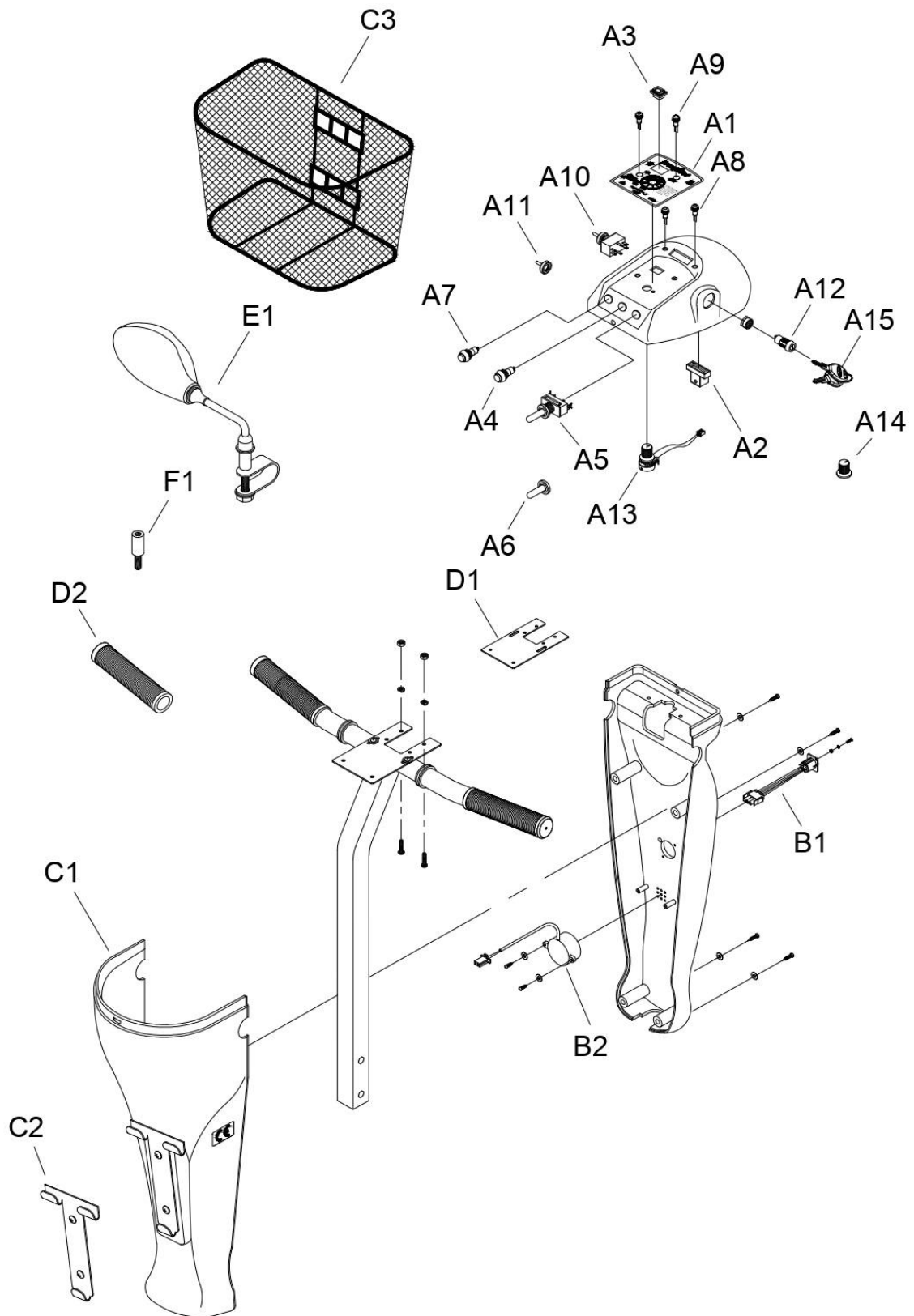

1. HANDLEBAR ASSEMBLY

| 販售 Selling | 項目 ITEM | 品號 Part Number | 中文品名 Part Name-CN | 英文品名 Part Name-EN | 數量 QTY | 備註 Remark | GBP |
|---------------|------------|-------------------|----------------------|--------------------------|-----------|---|-----|
| | A1-F1 | | | | | | |
| | A1-A14 | AA01-0314-◎ | 把手上蓋總成 | Top console cover assy. | 1 | ◎=R1 : Red、 B2 : Blue | |
| | A1 | PL01-0103-A | 面板貼紙 | Sticker | 1 | | |
| | A2 | PKE1-0700 | 電錶 | Battery meter | 1 | | |
| | A3 | PAE1-0800 | 大燈開關 | Head light switch | 1 | | |
| | A4 | PKE1-0103 | 喇叭開關 | Horn button | 1 | | |
| | A5 | PKE1-0105 | 搖頭開關 | Indicator switch | 1 | | |
| | A6 | PP01-0200 | 搖頭開關蓋 | Indicator switch cap | 1 | | |
| | A7 | PKE1-0101 | 警示開關 | Warning switch | 1 | | |
| | A8 | PKE1-0802 | LED指示燈(紅) | Status light(Red) | 1 | | |
| | A9 | PKE1-0800 | LED指示燈(綠) | Status light(Green) | 3 | | |
| | A10 | PKE1-0104 | 全速/半速開關 | HI/LO speed switch | 1 | | |
| | A11 | PP01-0201 | 全半速開關蓋 | HI/LO speed switch cap | 1 | | |
| | A12 | PM01-0100 | 鑰匙開關 | Key switch | 1 | | |
| | A13 | PAE1-0100-MO | 20KVR小總成 | 20KVR Potentiometer | 1 | W/speed knob | |
| | A14 | PP01-0500 | 速度旋鈕 | Speed knob | 1 | | |
| | A15 | PM90-0900 | 鑰匙 | Key | 1 | | |
| | B1-B2 | AA02-0200-◎ | 把手後蓋總成 | Tiller rear cover assy. | 1 | ◎=R1 : Red、 B2 : Blue | |
| | B1 | PAE1-0404-NP-A00 | 充電座小總成 | Charger socket assy. | 1 | | |
| | B2 | PKE1-0603 | 喇叭 | Horn | 1 | | |
| | C1 | AA03-0200-◎ | 把手前蓋總成 | Tiller front cover assy. | 1 | ◎=R1 : Red、 B2 : Blue (W/Basket hook) | |
| | C2 | PM03-0300-D1 | 籃子掛鉤 | Basket hook | 1 | | |
| | C3 | PM90-0100 | 籃子 | Basket | 1 | | |
| | D1-D2 | PA01-A300 | T型把手小總成 | Tiller Handlebar assy. | 1 | | |
| | D1 | PM02-0105 | 5KVR固定鐵片 | Potentiometer plate | 1 | | |
| | D2 | PP02-0209 | 握套泡棉 | Hand grip | 1 | | |
| | E1 | PP90-0203-R | 後照鏡-右 | Mirror(Right) | 1 | | |
| | F1 | PM03-0400 | 後視鏡墊高片 | Spacer for mirror | 1 | | |
| | | | | | | | |
| | | | | | | | |
| | | | | | | | |
| | | | | | | | |

2. CHASSIS COVER ASSEMBLY

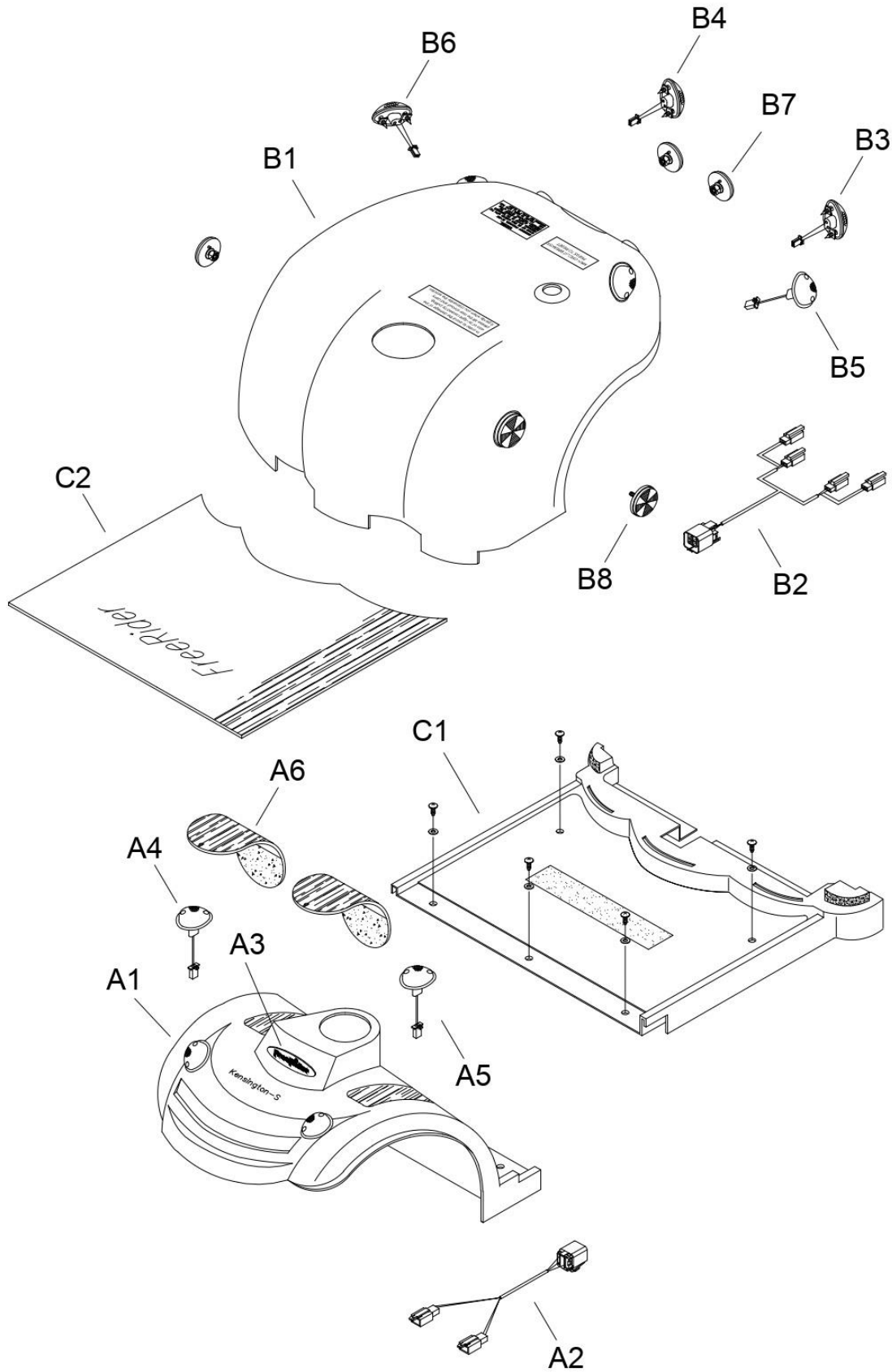

2. CHASSIS COVER ASSEMBLY

| 販售 Selling | 項目 ITEM | 品號 Part Number | 中文品名 Part Name-CN | 英文品名 Part Name-EN | 數量 QTY | 備註 Remark | GBP |
|---------------|------------|-------------------|----------------------|------------------------------|-----------|---------------------------|-----|
| | A1-C2 | | | | | | |
| | A1-A6 | AA04-0916-◎ | 前車殼總成 | Front chassis cover assy. | 1 | ◎=R1 : Red 、 B2 : Blue | |
| | A1 | PP04-0113-◎ | 前車殼 | Front chassis cover | 1 | ◎=R1 : Red 、 B2 : Blue | |
| | A2 | PKE3-0401 | 前方向燈線空中接頭 | Front indicator adapter wire | 1 | | |
| | A3 | PL00-0100 | 橢圓型貼紙 | Sticker | 1 | Freerider | |
| | A4 | PAE3-0200-L | 方向燈小總成-左 | Indicator assy.(Left) | 1 | 24V | |
| | A5 | PAE3-0200-L/R | 方向燈小總成-後左/前右 | Indicator assy.(Right) | 1 | Front/24V | |
| | A6 | PP04-0404 | 止滑踏墊 | Foot mat | 2 | | |
| | B1-B8 | AA05-0818-◎ | 後車殼總成 | Rear chassis cover assy. | 1 | ◎=R1 : Red 、 B2 : Blue | |
| | B1 | PP05-0125-◎ | 後車殼 | Rear chassis cover | 1 | ◎=R1 : Red 、 B2 : Blue | |
| | B2 | PKE3-0501-2 | 後方向燈空中接頭 | Rear indicator adapter wire | 1 | | |
| | B3 | PAE3-0100-L | 後大燈小總成-左 | Tail light assy.(Left) | 2 | 24V | |
| | B4 | PAE3-0100-R | 後大燈小總成-右 | Tail light assy.(Right) | 2 | 24V | |
| | B5 | PAE3-0200-L/R | 方向燈小總成-後左/前右 | Indicator assy.(Left) | 1 | Rear/24V | |
| | B6 | PAE3-0200-R | 方向燈小總成-右 | Indicator assy.(Right) | 1 | 24V | |
| | B7 | PA05-A400-R | 反光片-紅色 | Reflector (Red) | 2 | | |
| | B8 | PA05-A400-Y | 反光片-黃色 | Reflector (Orange) | 2 | | |
| | C1 | AA06-0200-D1 | 腳踏板總成 | Footplate cover assy. | 1 | | |
| | C2 | PP04-0508 | 地毯 | Carpet | 1 | | |
| | | | | | | | |
| | | | | | | | |
| | | | | | | | |
| | | | | | | | |
| | | | | | | | |
| | | | | | | | |
| | | | | | | | |
| | | | | | | | |
| | | | | | | | |
| | | | | | | | |
| | | | | | | | |
| | | | | | | | |
| | | | | | | | |

3. FRONT CHASSIS ASSEMBLY

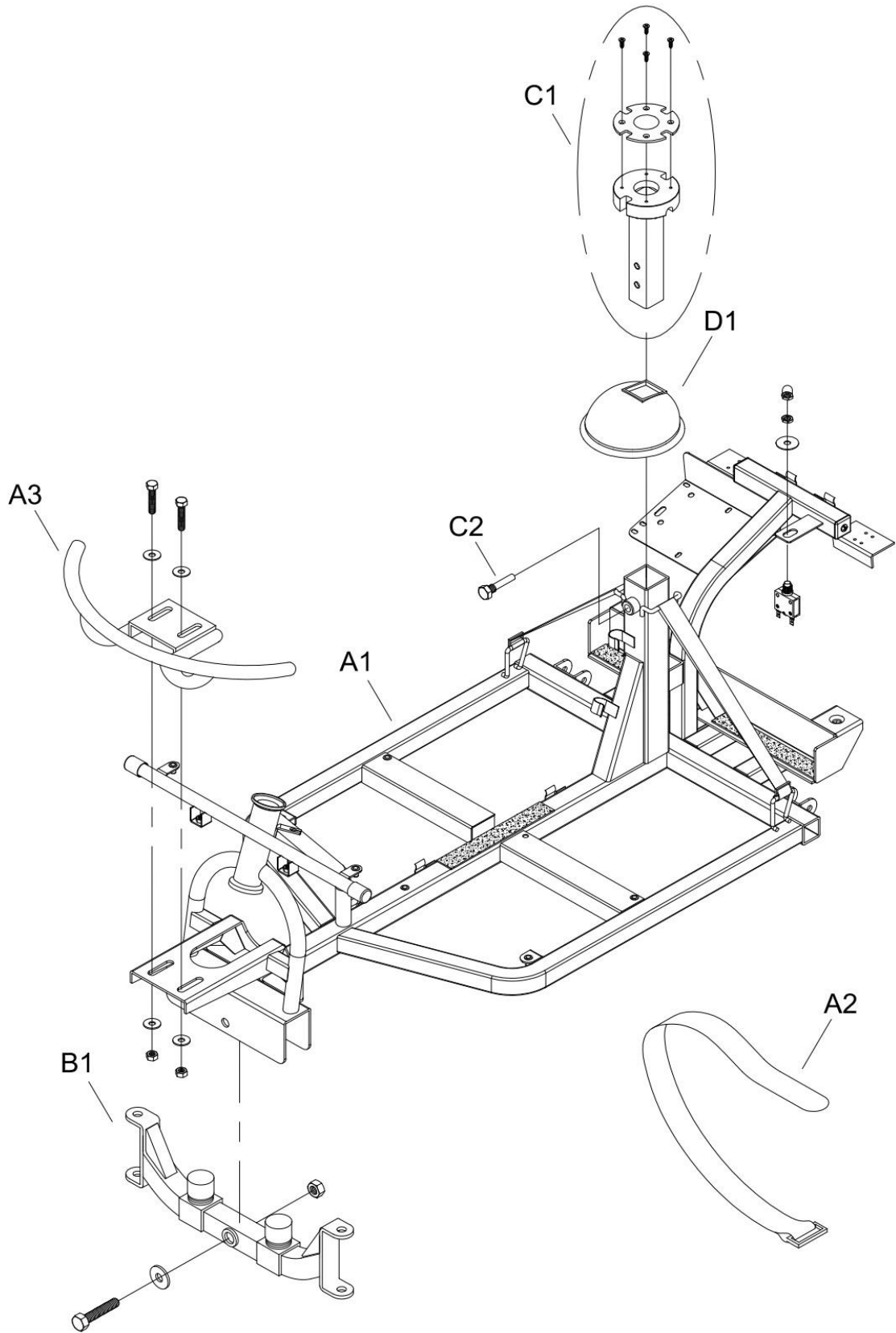

4. REAR CHASSIS ASSEMBLY-DRIVE SYSTEM

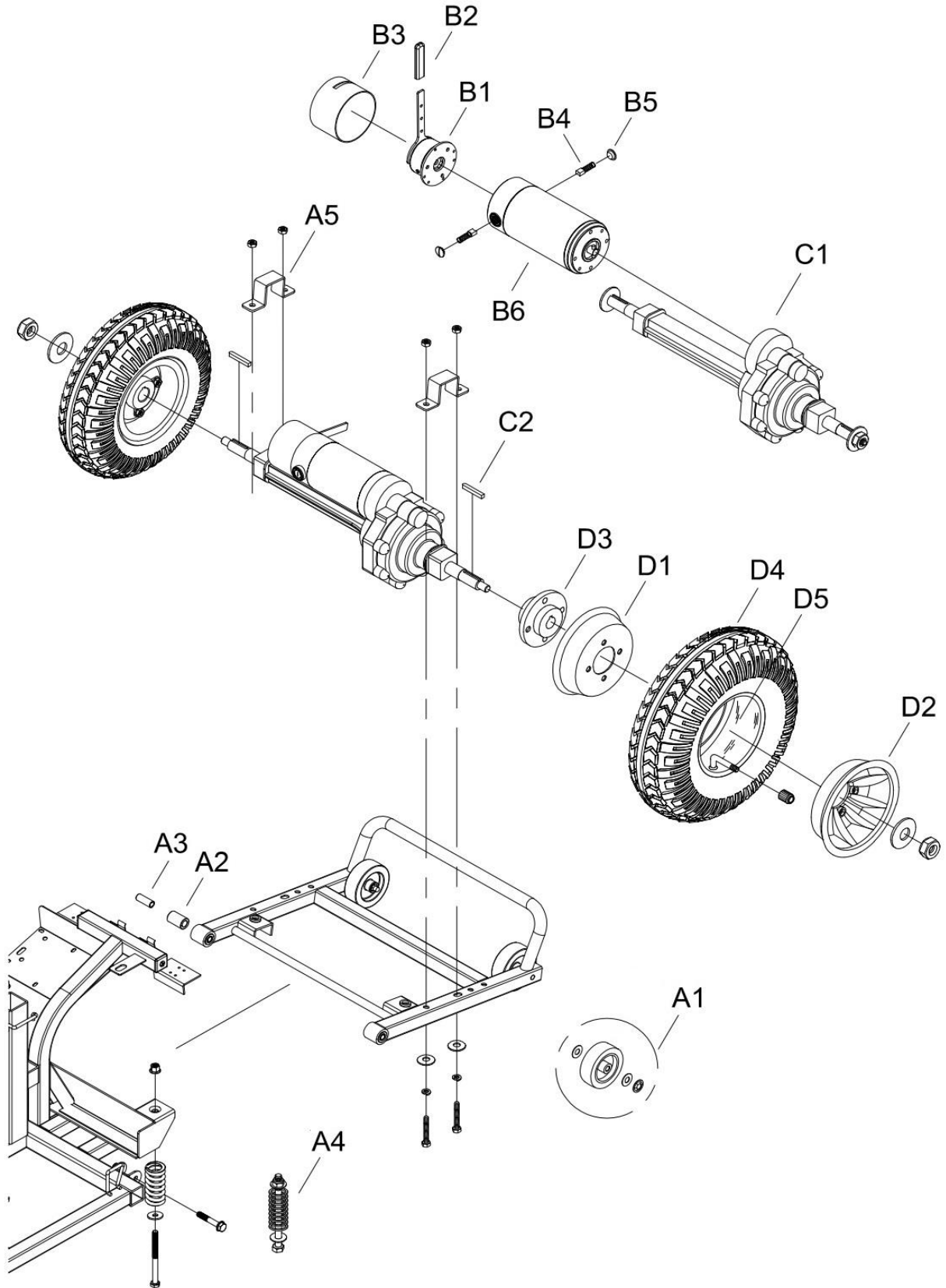

5. STEERING

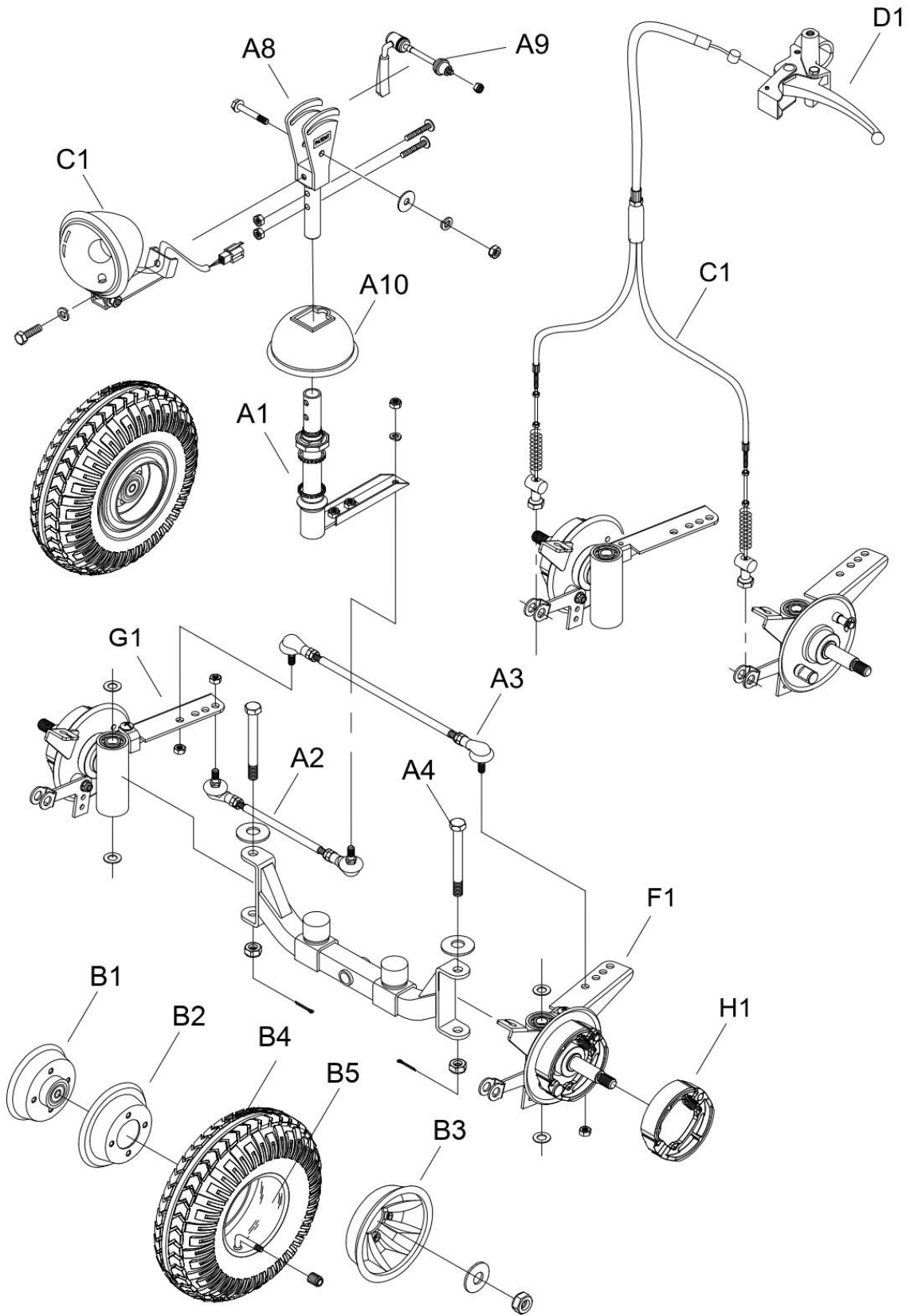

6. SEAT ASSEMBLY

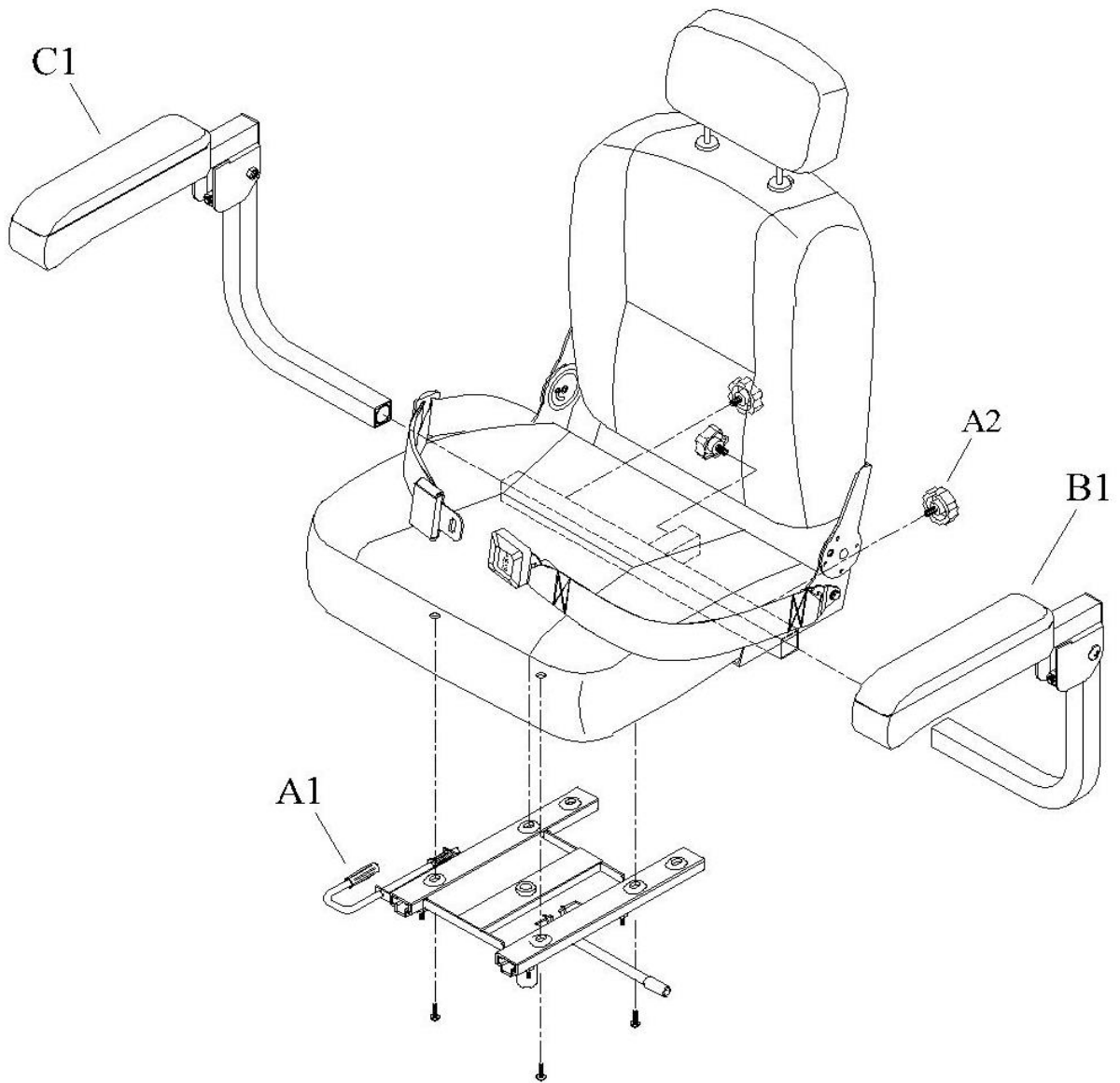

7. CONSOLE AND WIRING SYSTEM

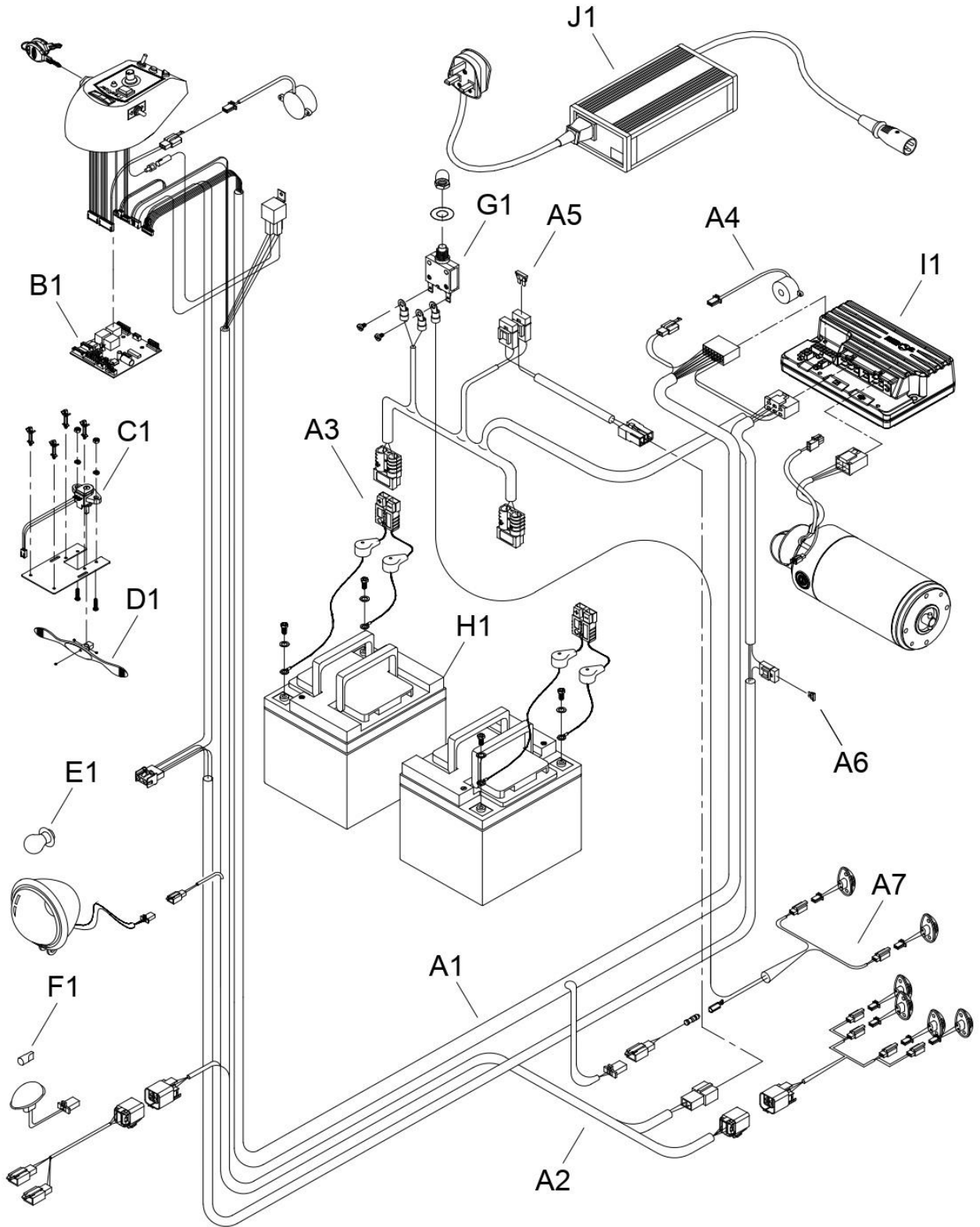

7. CONSOLE AND WIRING SYSTEM

| 販售 Selling | 項目 ITEM | 品號 Part Number | 中文品名 Part Name-CN | 英文品名 Part Name-EN | 數量 QTY | 備註 Remark | GBP |
|---------------|------------|-------------------|----------------------|----------------------|-----------|--------------|-----|
| | A1-J1 | | | | | | |
| | A1 | PKE2-0237 | 主線 | Main cable | 1 | | |
| | A2 | PKE3-0612-1 | 前後大燈線 | Light cable | 1 | | |
| | A3 | PAE3-0301-1 | 電源線小總成 | Battery cable assy. | 2 | | |
| | A4 | PKE1-0601 | 倒車喇叭 | Horn | 1 | | |
| | A5 | PKE1-1002 | 保險絲 | Fuse | 1 | 10A | |
| | A6 | PKE1-1002-2 | 保險絲 | Fuse | 1 | 10A | |
| | A7 | PKE1-0232-1 | 1P剎車燈用信號線 | Cable | 1 | | |
| | B1 | PAE1-0309-1 | PCB板 | P.C.B | 1 | | |
| | C1 | PA02-A204-J5 | 5KVR總成 | 5KVR Potentiometer | 1 | | |
| | D1 | PM02-0300-D2 | 撥桿 | Wig wag accelerator | 1 | | |
| | E1 | PK00-0109 | 燈泡 | Bulb | 1 | 24V/25W | |
| | F1 | PK00-0101 | 燈泡 | Bulb | 8 | 24V/5W | |
| | G1 | PKE2-0404 | 無熔絲開關 | Circuit breaker | 1 | 70A | |
| | H1 | PK90-0206-KL | 電瓶 | Battery | 2 | 50A | |
| | I1 | PKE2-0122 | 下控制器 | Controller | 1 | DS90 | |
| | J1 | PK90-H502-1 | 充電機 | Charger | 1 | 5A | |
| | | | | | | | |
| | | | | | | | |
| | | | | | | | |
| | | | | | | | |
| | | | | | | | |
| | | | | | | | |
| | | | | | | | |
| | | | | | | | |
| | | | | | | | |
| | | | | | | | |
| | | | | | | | |
| | | | | | | | |
| | | | | | | | |
| | | | | | | | |
| | | | | | | | |
| | | | | | | | |
| | | | | | | | |
| | | | | | | | |
| | | | | | | | |
| | | | | | | | |
| | | | | | | | |
| | | | | | | | |
| | | | | | | | |
| | | | | | | | |
| | | | | | | | |
| | | | | | | | |
| | | | | | | | |
| | | | | | | | |
| | | | | | | | |
| | | | | | | | |
| | | | | | | | |
| | | | | | | | |